

# CRYSTAL SEMICONDUCTOR PRODUCT GUIDE

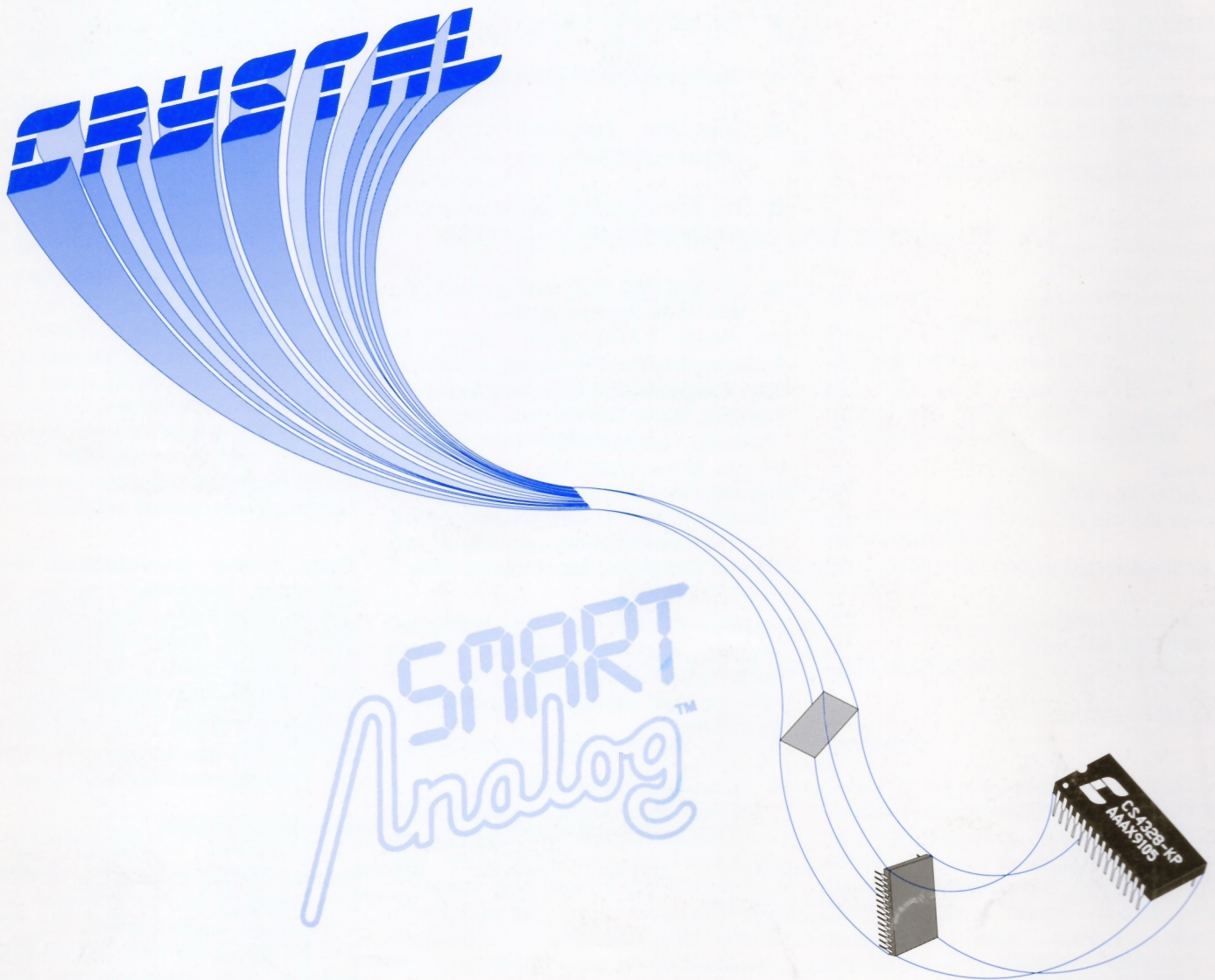

SMART  
Analog™

September 1993

# CRYSTAL SEMICONDUCTOR CORPORATION

## CONTENTS

<b>TELECOMMUNICATIONS &amp; ETHERNET LAN</b> . . . . .	<b>3</b>
T1/PCM-30/ISDN Line Interfaces . . . . .	4
Quartz Crystals . . . . .	4
T1 Framers/Transceivers . . . . .	5
Jitter Attenuators . . . . .	5
DTMF Receivers . . . . .	6
Ethernet Transceiver . . . . .	6
<b>ANALOG-TO-DIGITAL CONVERTERS</b> . . . . .	<b>7</b>
General Purpose ADC's . . . . .	8
Industrial ADC's . . . . .	9
<b>DIGITAL AUDIO PRODUCTS</b> . . . . .	<b>11</b>
Volume Control . . . . .	12
Multimedia Codecs . . . . .	12, 13
Digital Audio DAC's . . . . .	14
Digital Audio ADC's . . . . .	15, 16
AES/EBU, S/PDIF Transmitters & Receivers . . . . .	16, 17
Synthesizers . . . . .	17
<b>SUPPORT</b> . . . . .	<b>18</b>
Software . . . . .	18
CDBCAPTURE . . . . .	18
Power Monitor . . . . .	18
<b>CUSTOMER SUPPORT</b> . . . . .	<b>19</b>
Evaluation Boards . . . . .	19
Military Std. 883 . . . . .	19
Die Sales . . . . .	19
<b>SALES OFFICES</b> . . . . .	<b>20</b>

At Crystal Semiconductor, our success is built on being the *most innovative* Analog Integrated Circuit company. We have an impressive string of "firsts" to back up that claim:

- The first monolithic T1 line interface.
- The first 16-bit monolithic analog to digital converter (ADC).
- The first CMOS Ethernet Transceiver
- The first monolithic Delta-Sigma ADC.
- The first monolithic 20-bit dc measurement ADC.
- The first monolithic signal processing ADC with 130 dB dynamic range.
- The first DAC SCF analog output filter with 97 dB dynamic range.

Achieving better performance, along with more integration, is a Crystal hallmark. For example, our CS5016 16-bit monolithic converter out-performs most hybrid devices; at lower cost, with better reliability and with consistent long-term stability. For our customers, this means better system performance with greater reliability as well as lower design and manufacturing costs.

SMART *Analog*<sup>TM</sup> design techniques uniquely combine complex analog functions with powerful digital circuitry to build the most capable analog circuits in the industry.

SMART *Analog*<sup>TM</sup> techniques have also yielded the world's best T1 line interface family. These parts incorporate programmable output pulse shapes to compensate for different cable lengths and a pullable crystal output oscillator yielding superb jitter attenuation capability.

Digital audio technology is rapidly supplanting traditional linear audio architectures. Crystal is the industry leader for A/D converters and D/A converters, based on our proprietary delta-sigma one-bit oversampling designs. Our devices have achieved global recognition because of their high level of integration, ease of use and superb sound quality. Crystal also supplies audio devices optimized for computer multimedia applications. Transmission of audio data between digital systems is facilitated by our family of AES/EBU & S/PDIF transmitters and receivers.

Crystal's most recent market entry is Local Area Network devices. Our chip set for Ethernet is industry's first 100% CMOS solution. The CS83C92 transceiver (TAP) chip is pin compatible to the industry-standard bipolar device and consumes only one-half the power.

Every Crystal Semiconductor product undergoes qualification testing before release to production. Both long-term and infant-mortality testing are used to identify any weaknesses. Qualification is performed on 3 non-consecutive lots using military specifications as guidelines (See Table below).

TEST	MIL STD 883C METHOD	CONDITION	INFANT MORTALITY TESTS		LONG-TERM RELIABILITY TESTS		
			DURATION	PASS/FAIL CRITERION	DURATION	PASS/FAIL CRITERION	CRYSTAL GOAL
OPERATING LIFE	1015 COND D	+125 °C, Dynamic Bias +/-5.5V Supplies	168 hrs	0.25%	1000 HRS	75 FITS ++ (25 °C/60%UCL 1.0 eV Act. Energy)	10 FITS + (25 °C/ 60% UCL)
TEMPERATURE HUMIDITY STRESS (Plastic Parts)		+85° C/85% RH Static Bias	168 hrs	1.0 LTPD	1000 HRS	3.0 LTPD	1.0 LTPD
TEMPERATURE CYCLING Hermetic Packages	1010.5 COND C	-65° C to + 150 °C Then Gross Leak Test	100 CYCLES	1.0 LTPD	1000 CYCLES	3.0 LTPD	1.0 LTPD
TEMPERATURE CYCLING Molded Packages	1010.5 COND B or *	-55° C to + 125 °C or -40° C to + 125 °C	100 CYCLES	1.0 LTPD	500 CYCLES	3.0 LTPD	1.0 LTPD
THERMAL SHOCK	1011.4 COND B or **	-55° C to + 125 °C or -40° C to + 125 °C *** Then Gross Leak Test	100 CYCLES	1.0 LTPD	500 CYCLES	3.0 LTPD	1.0 LTPD
AUTOCLAVE (Plastic Parts)		+121 °C/100% RH 2 Atmosphere, No Bias	48 HRS	1.0 LTPD	144 HRS	3.0 LTPD	1.0 LTPD
CENTRIFUGE	2001	30 Kg/Y1 Axis				5.0 LTPD	1.0 LTPD
ELECTROSTATIC DISCHARGE	3015			1500V-0 Fail	5 UNITS, ALL PINS	1500V-0 FAIL	4000V
LATCH UP		dc Current		100 mA-0Fail	5 UNITS, ALL PINS	100mA-0 FAIL	200mA

\* JEDEC STD 22-B A 104 COND B

\*\* JEDEC STD 22-B A 106 COND C

\*\*\* For hermetic Packages Only

+ Equivalent to 50 FITS, 70 C/60% ULC, 0.7 eV

++ Equivalent to 300 FITS, 70 deg. C/60% UCL, 0.7 eV

## Low Power T1, PCM-30 and ISDN Primary Rate Line Interface Circuits

Crystal Semiconductor offers a broad family of low power CMOS PCM line interface circuits, with each device optimized for a unique system application. The CS6152, CS61535A, CS61574A and CS61575 are recommended for use in new designs. Since introducing the industry's first T1 and PCM-30 line interface circuits (the CS61534 and CS61544), we have shipped more CMOS PCM line interface ICs than any other vendor worldwide. Crystal Semiconductor's leadership continues with the best in pulse shapes, jitter attenuation, jitter tolerance and low power consumption.

Product	CS6152	CS61535A	CS61574A	CS61575
Rate	T1	T1 & PCM-30	T1 & PCM-30	T1 & PCM-30
Receiver Functions	Data Slicer	Clock & Data Recovery	Clock & Data Recovery & Jitter Atten.	Clock & Data Recovery & Jitter Atten.
Transmitter Functions	Driver	Jitter Atten. & Driver	Driver	Driver
Serial Control Port	-	✓	✓	✓
DIP Package	24-pin, .3"	28-pin, .6"	28-pin, .6"	28-pin, .6"
Surface Mount	28-pin PLCC	28-pin PLCC	28-pin PLCC	28-pin PLCC
AMI/B8ZS/HDB3 Coder	-	✓	✓	✓
Jitter Tolerance of Receiver	> 300 UI	> 300 UI	28 UI	138 UI

## T1 Transceiver

Our CS2180B T1 Transceiver is a perfect companion to our T1 line interface ICs. This device handles encoding and decoding of all T1 frame formats (D4, SLC-96 and T1DM and ESF). Serial interface and control registers make it simple to configure from a microprocessor, including per-channel control options. Packages available include 40-pin DIP or 44-lead PLCC.

## Quartz Crystals

To complement our family of T1 Line Interface circuits, Crystal Semiconductor supplies pullable quartz crystals. The CXT6176 (for T1 applications at 1.544 Mbps) and CXT8192 (for PCM-30 applications at 2.048 Mbps) are designed for 100% compatibility with our PCM line interface and jitter attenuator circuits.

## DTMF Receivers

Crystal has improved on industry standard DTMF receiver ICs while maintaining 100% pin compatibility. Our device features on-chip filters which offer the best possible signal-to-noise ratio allowing highly accurate decoding of telephone tones. Our CS20X family requires half the power of industry alternatives while providing 22 dB more dial tone rejection and better latch-up immunity.

## LINE INTERFACE COMPARISON TABLE

**CS6152:** Basic DSX-1 driver and receive buffer. For low power cards using digital-ASIC clock recovery. Ideal for trunk card bays where T1 density is limited by heat dissipation.

**CS61535A:** Enhanced transmit-side jitter attenuator supports SONET VT1.5 and VT2, and other high speed transmission systems such as digital microwave radio and M13 multiplexers.

### CS61574A and CS61575:

Receive-side jitter attenuation supports loop-timing in customer-premises equipment (which needs to meet AT&T 62411) and in channel banks.

## LINE INTERFACE APPLICATIONS

### Jitter Attenuation Circuits

Our jitter attenuation technology is available stand-alone for a wide variety of applications. The CS61600 is ideal for T1 and PCM-30 applications while the CS80600 attenuates jitter in T2, 2nd-level CEPT lines and Token Ring LANs. Both attenuators can be used with external divide circuits to handle low frequencies.

### Ethernet

Crystal is the first company to bring the benefits of low-power CMOS technology to Ethernet/Cheapernet transceivers. The CS83C92C uses up to 40% less power than the DP8392A and DP8392B. This translates into increased reliability and compatibility with surface mount technology. The CS83C92C is the first Ethernet transceiver which is fully compliant with ISO/IEEE 802.3.

# TELECOMMUNICATIONS

## CS6152

### T1 Analog Interface

- \* Low power
- \* EXPERT Pulse™ line driver
- \* AMI to TTL receiver
- \* 300 mil DIP or PLCC package

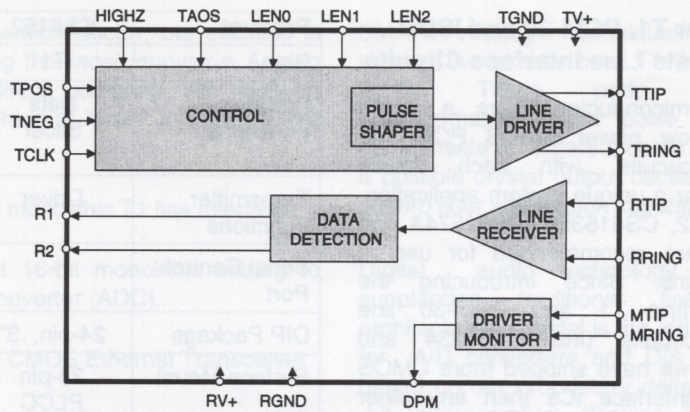

## CS61535A

### T1 & PCM-30 Line Interface

- \* EXPERT Pulse™ line driver
- \* Data and clock recovery
- \* Transmit-side jitter attenuator
- \* B8ZS/HDB3/AMI encoders/decoders

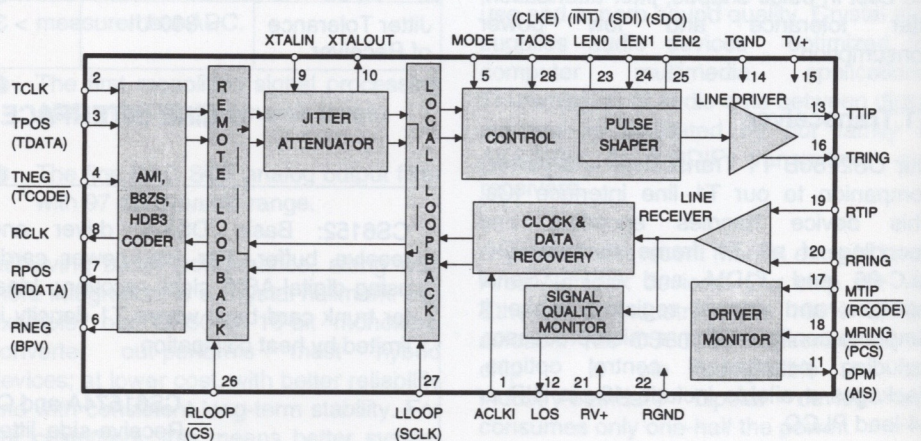

## CS61574A

### T1 & PCM-30 Line Interface

- \* EXPERT Pulse™ line driver
- \* Data and clock recovery
- \* Receive-side jitter attenuator
- \* Compliant to AT & T 62411

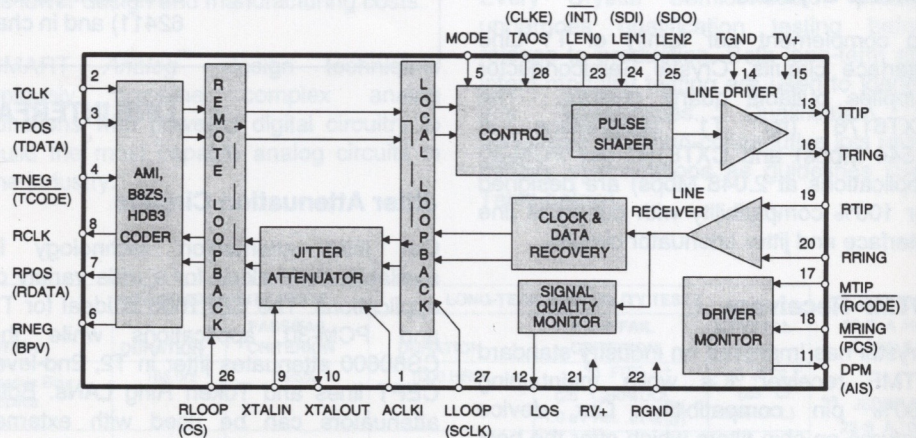

## CXT6176, CXT8192

### Quartz Crystal

- \* 6.176 MHz or 8.192 MHz
- \* Optimized pulling characteristics
- \* Suitable for use with Crystal line interface integrated circuits and jitter attenuators.

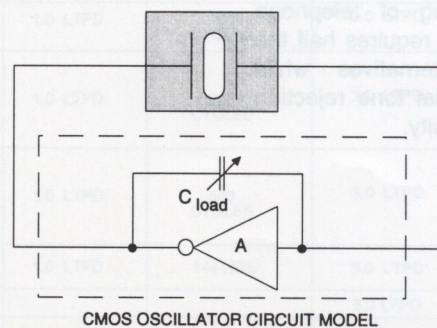

## CS2180A, CS2180B

### T1 Framing I.C.

- \* D4 & ESF formats
- \* CS2180B also supports SLC-96 & T1DM formats
- \* CS2180B is pin compatible with CS2180A, DS2180A, DS2180

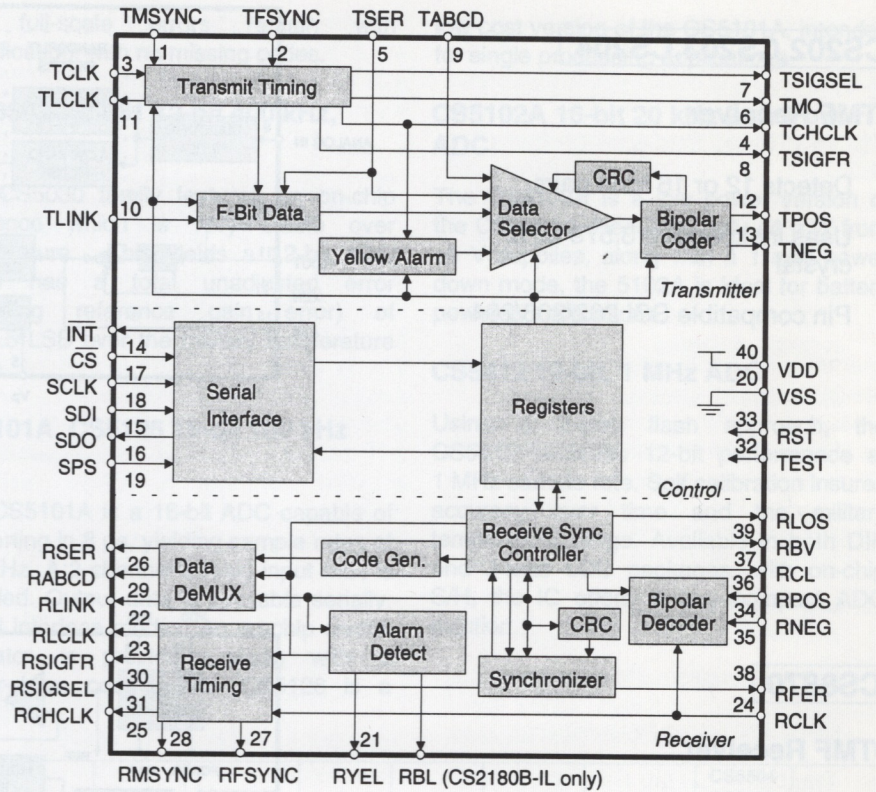

## CS61600

### T1 (1.544 MHz) or PCM-30 (2.048 MHz) Jitter Attenuator

- \* Attenuates > 50 Hz jitter
- \* Tolerates at least 7 U.I.
- \* 50 mW power

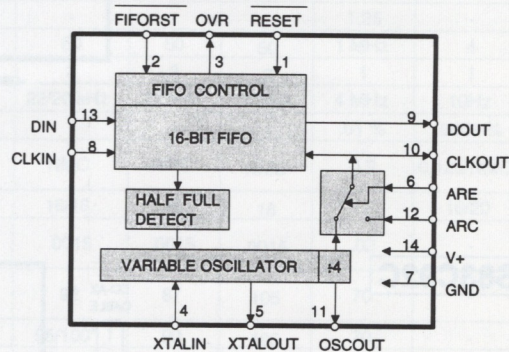

## CS80600

### General Purpose Jitter Attenuator

- \* 4.5 MHz to 8.5 MHz clock
- \* Tolerates at least 3 U.I.
- \* T1C, T2, CEPT2 & 2nd order multiplexers & Token ring applications

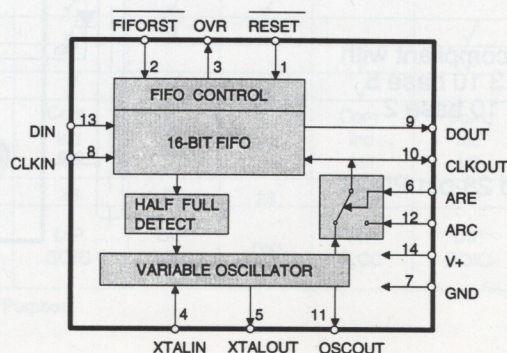

## CS202, CS203, CS204

### DTMF Receiver

- \* Detects 12 or 16 tone pairs
- \* Uses inexpensive 3.579 MHz crystal
- \* Pin compatible SSI 202/203/204

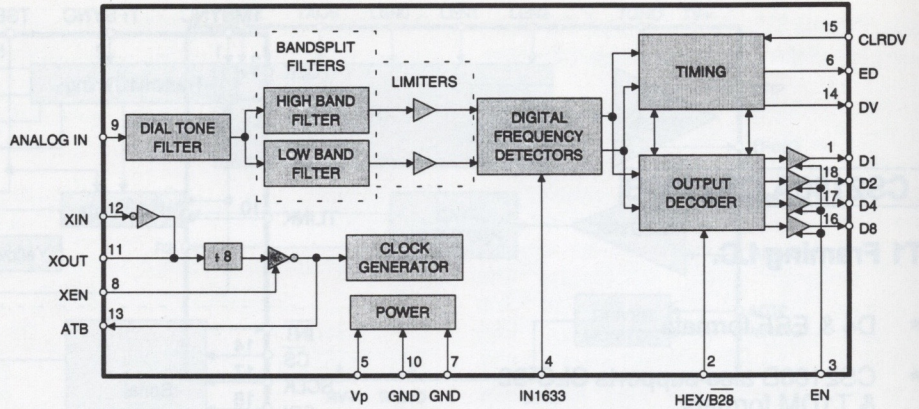

## CS8870

### DTMF Receiver

- \* Adjustable receiver sensitivity
- \* Adjustable detect and release time
- \* Pin compatible with MT8870B

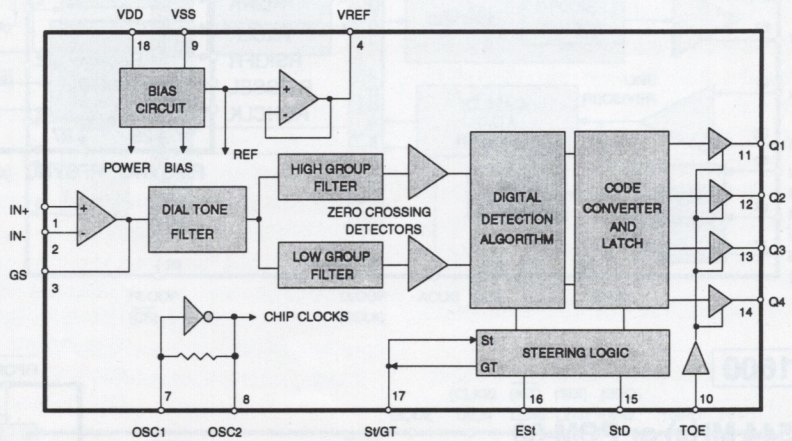

## CS83C92A, CS83C92C

### Ethernet Co-ax Transceiver

- \* Low power CMOS
- \* Pin compatible with National DP8392A/B
- \* CS83C92C is compliant with ISO/IEEE 802.3 10 base 5 (Ethernet) and 10 base 2 (Cheapernet)
- \* 16-pin DIP and 28-pin PLCC

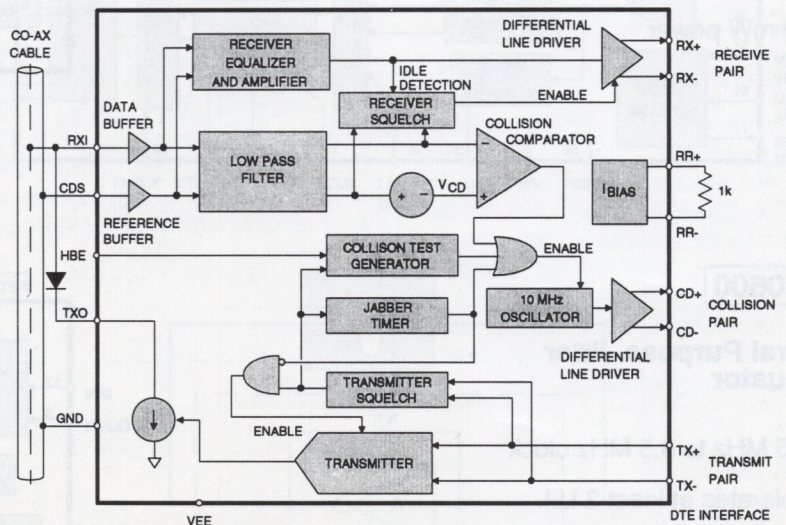

# ANALOG TO DIGITAL CONVERTERS

Using SMART Analog technology, Crystal Semiconductor has created a family of CMOS A/D Converters which feature patented on-chip, self-calibrating architectures to maintain accuracy and linearity over their full temperature range and device lifetime. All of our A/D Converters features an on-chip sample and hold, and are manufactured in low-power CMOS.

## General Purpose ADC's

### CS5012A, CS5014, CS5016 SAR Family

The CS5012A, CS5014 and CS5016 converters have 12, 14 & 16 bits of resolution respectively, with conversion times of 7  $\mu$ s to 16  $\mu$ s. The converters are tested for static and dynamic performance, at full rated conversion speed. On-chip self-calibration ensures that linearity, offset

and full-scale errors remain with specification, with no missing codes.

### CS5030, CS5031 12-bit 400 kHz, ADC

The CS5030 family features an on-chip reference which is very stable over temperature. This yields a 12-bit ADC which has a total unadjusted error (including reference gain error) of  $< \pm 0.5$  LSB over the military temperature range.

### CS5101A, CS5126 16-bit 100 kHz ADC

The CS5101A is a 16-bit ADC capable of converting in 8  $\mu$ s, yielding sample rates of 100 kHz. A 2-channel analog input mux is included. Output data is available serially, with 4 interface modes. An on-chip crystal oscillator is provided, along with a power-down control. The CS5126 is a

low-cost version of the CS5101A, intended for single processing applications.

### CS5102A 16-bit 20 kHz Low Power ADC

The CS5102A is a low power version of the CS5101A. Requiring only 44 mW from  $\pm 5$  V supplies, along with a 1 mW power down mode, the 5102A is ideal for battery powered applications.

### CS5412 12-bit, 1 MHz ADC

Using a 2-step flash approach, the CS5412 achieves 12-bit performance at 1 MHz sample rate. Self calibration insures accuracy over time and the military temperature range. Available in both DIP and J-lead LCC packages, with on-chip S/H, the IC offers a very compact ADC solution.

Specifications	CS5012A CS5014 CS5016	CS5030 CS5031	CS5101A CS5102A CS5126	CS5317	CS5321 CS5322 CS5323 CS5324	CS5326/7 CS5328/9 CS5336/7 CS5338/9	CS5345 CS5349	CS5389	CS5412	CS5501 CS5503	CS5504 CS5505 CS5506 CS5507 CS5508 CS5509	CS5516 CS5520
Application	GP	GP	GP	Modem	Seismic	Audio	Audio	Audio	GP Fast	DC Measurement		
Resolution (bits)	12/14/16	12	16	16	24	16/18	16	18	12	16/20	16/20	16/20
Conversion Time (us)	7/14/16	2	8/40	-	-	-	-	-	1.25	-	-	-
Throughput (kHz)	100/56/50	400	100/20	20	-	50	50	50	1 MHz	4	60/100Hz	60Hz
Number of Inputs	1	1	2	1	1	2	2	2	1	1	1/2/4	1
Input Bandwidth	-	-	-	10 kHz	500 Hz	22/20 kHz	22 kHz	22kHz	4 MHz	10Hz	10 Hz	12Hz
Integral Non-Linearity	.006/.002/.001 %	.25LSB	.0015%	-	-	-	-	-	.01 %	.0007 %	.0015 %	.0007 %
Differential ( $\pm$ LSB) Non-Linearity	0.25/0.25/NMC	0.5	NMC	NMC	NMC	NMC	NMC	NMC	0.9	0.125/NMC	0.125	0.5
No Missing Codes	12/14/16	12	16	16	20	16/18	16	18	12	16/20	16/18	16/20
Total Harmonic Distortion (%)	.008/.003/.001	-80 dB	.001	.007	.0003	.0015	.0015	.0015	.02	-	-	-
Signal-to-Noise plus Distortion (dB)	73/83/92	72	92	80	-	92	87	105	70	-	-	-
Dynamic Range (dB)	73/83/92	72	92	84	120	95/100*	90	105	70	-	-	-
Power Needed (mW)	150	50	280/44	220	150	450/400	100/325	550	750	25	3	30
Conversion Method	Succ. Approx.	Succ. Approx.	Succ. Approx.	Delta Sigma	Delta Sigma	Delta Sigma	Delta Sigma	Delta Sigma	2-Step Flash	Delta Sigma	Delta Sigma	Delta Sigma
Power Down Mode			✓		✓	✓	✓	✓		✓	✓	✓
On-Chip Sample and Hold	✓	✓	✓	✓	✓	✓	✓	✓	✓	✓	✓	✓
On-Chip V. Ref		✓		✓		✓	✓	✓			✓	✓
On-Chip Filtering				✓	✓	✓	✓	✓		✓	✓	✓
Statically Tested	✓	✓	✓						✓	✓	✓	✓
Dynamically Tested	✓	✓	✓	✓	✓	✓	✓	✓	✓			
Temperature Range	Com Ind Mil	Com Ind Mil	Com Ind Mil	Com Ind Mil	Com Ind	Com Ind Mil	Com Ind	Com	Com Ind Mil	Com Ind Mil	Ind Mil	Ind Mil
Number of Pins (DIP)	40	24	28	18	28	28	28	28	40	20	20/24	24
Packages	DIP PLCC LCC	DIP SOIC	DIP PLCC LCC	DIP SOIC	PLCC	DIP SOIC	DIP SOIC	DIP	DIP JLCC	DIP SOIC	DIP SOIC	DIP SOIC

NMC=No Missing Codes

\* CS5328 In Mono Mode

GP=General Purpose

# GENERAL PURPOSE ADC's

## CS5012A, CS5014, CS5016

### 12, 14, 16-bit Self Calibrating ADC's

- \* 50 kHz to 100 kHz sample rate
- \* 8  $\mu$ s to 16  $\mu$ s conversion time
- \* 0.001% linearity
- \* No missing codes
- \* Low power consumption 150mW

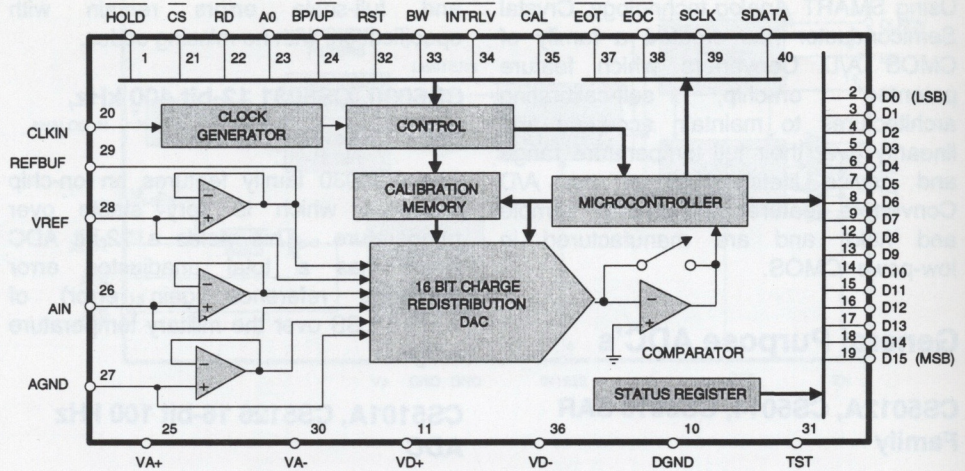

## CS5030, CS5031

### 12-bit, 400 kHz, ADC's

- \* 0.5  $\mu$ s Track and Hold
- \* On Chip 1 ppm/ $^{\circ}$ C reference
- \* Total Unadjusted Error  $\pm 1/2$  LSB
- \* 50 mW power

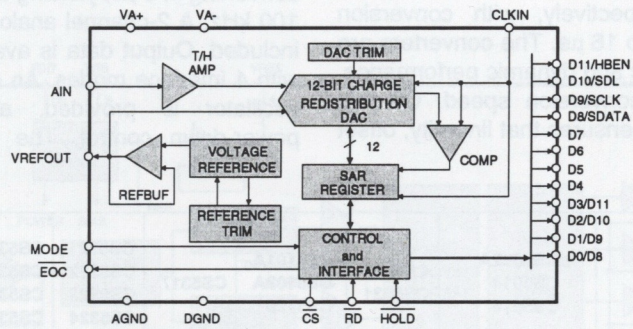

## CS5101A, CS5102A, CS5126

### 16-bit Self Calibrating ADC's

- \* 100 kHz or 20 kHz sample rate
- \* 8  $\mu$ s or 44  $\mu$ s conversion time
- \* 280 mW or 44 mW power consumption
- \* No missing codes
- \* Small 28 pin DIP or PLCC package

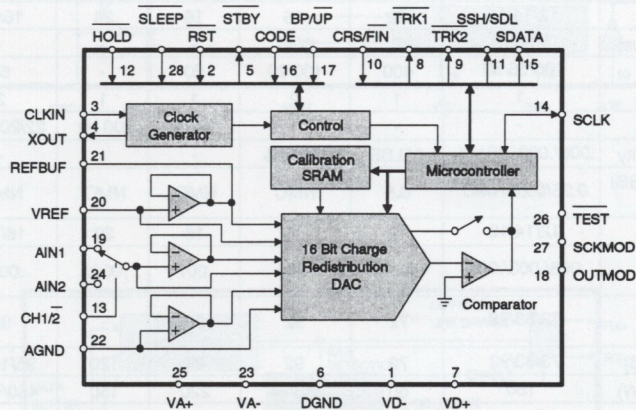

## CS5412

### 12-bit Self Calibrating ADC

- \* 1 MHz sample rate
- \* Built in track & hold
- \* 72 dB dynamic range
- \* Linearity  $\pm 3/4$  LSB
- \* No missing codes
- \* 750 mW power consumption

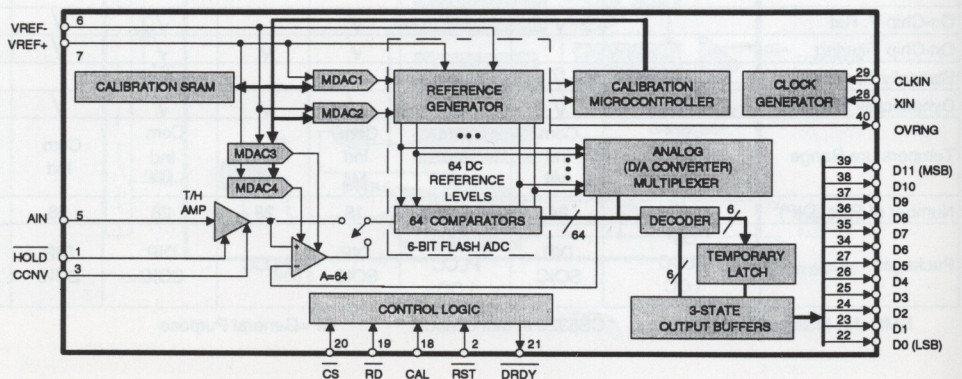

# INDUSTRIAL ADC's

Intended for dc and low frequency measurements, Crystal offers a variety of ADC's for the weigh scale, process control, medical and seismic industries.

## CS5501, CS5503 16/20-bit DC Measurement ADC

The CS5501 and CS5503 feature an on-chip, 6-pole, low-pass filter, with adjustable corner frequencies from 0.1 Hz to 10 Hz. The ADC's achieve linearity errors of 0.0007%, with no missing codes. A highly flexible serial interface, along with 25 mW power consumption, all in a 20 pin package, make the parts ideal for weigh scale and process control applications. The CS5503 is the 20-bit version of the CS5501, offering increased dynamic range, often removing the need for external gain scaling.

## CS5504/5/6/7/8/9 1, 2, & 4-channel, 16/20-bit DC Measurement ADC

Very low power consumption of 1.5 mW, along with a 4-channel input mux, make

this part ideal for process control and hand held meter applications. These ADC's are available in 16 or 20 bit versions, with 1, 2, or 4 channel inputs and DIP or surface mount packages.

## CS5516, CS5520 16/20-bit Bridge Transducer ADC

The CS5516 and CS5520 are complete solutions for digitizing low level signals from strain gauges, load cells and pressure transducers. Any family of mV output transducers, including those needing bridge excitation, can be directly interfaced to the CS5516 or CS5520. The devices offer an on-chip software programmable instrumentation amplifier, choice of AC or DC bridge excitation, software selectable reference and signal demodulation.

## CS5321, CS5322, CS5323, CS5324, 24-bit Variable Bandwidth ADC

The CS5323 or CS5321 modulator, combined with the CS5322 digital filter,

offers >120 dB dynamic range in the DC to 500 Hz frequency band. Seven different filter corner frequencies and output update rates are offered, allowing the ADC to be optimized for different types of seismic measurements. The CS5324 includes a modulator and the first stage of digital filtering, allowing users to implement their own final filter stage.

## CS5317 16-bit Voice Band ADC

The CS5317 is well suited for a wide range of voiceband applications, from speech recognition to passive sonar. An on-chip PLL/Clock generator makes the part perfect for high-performance modems. The device features a 20 kHz word rate, a 10 kHz bandwidth, 84 dB dynamic range and 80 dB THD.

## CS5336 Audio Bandwidth ADC's

Selected members of our audio ADC family will be offered in industrial or military versions (See the Digital Audio Section).

### CS5317

#### 16-bit, delta-sigma ADC

- \* Internal track & hold
- \* On-chip reference
- \* Digital filter
- \* 84 dB dynamic range
- \* 10 Hz to 10 kHz bandwidth
- \* 20 kHz output word rate

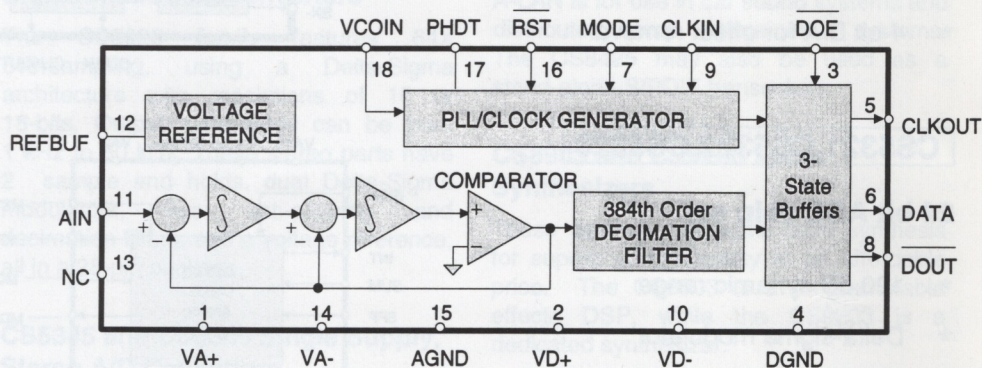

### CS5501, CS5503

#### 16 or 20-bit CMOS ADC

- \* dc to 10 Hz bandwidth
- \* 4 kHz output word rate
- \* On chip digital filter rejects 50 and 60 Hz
- \* 0.0015% linearity
- \* DNL  $\pm 1/8$  LSB
- \* Self and system calibration
- \* 25 mW power, 10  $\mu$ W sleep mode

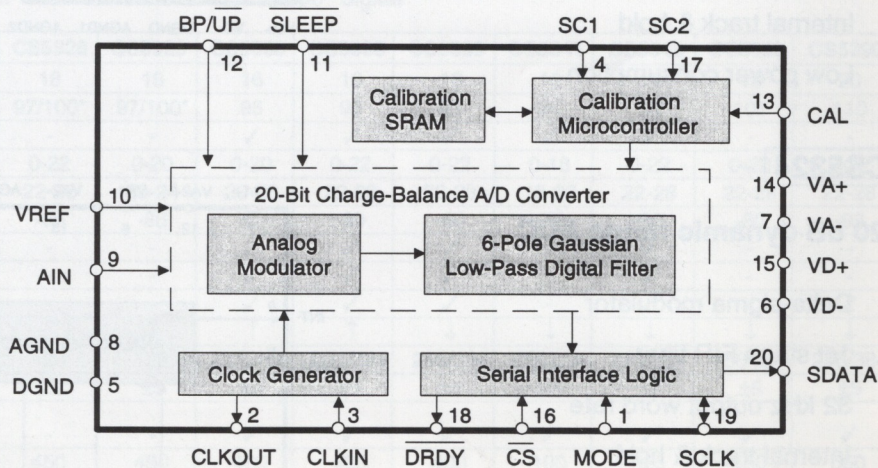

# INDUSTRIAL ADC's

## CS5504, CS5505, CS5506, CS5507, CS5508, CS5509

### 16 or 20 bit CMOS ADC

- \* Very low power consumption of 1.5mW
- \* dc to 10 Hz measurements
- \* Built-in digital filter rejects 50 and 60 Hz
- \* 1, 2, or 4 channel versions
- \* Internal track & hold

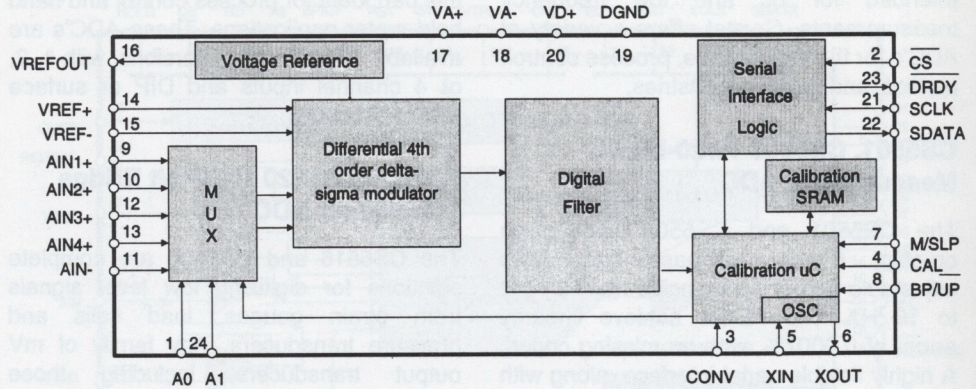

The CS5505/6 are illustrated. The CS5507/8 are single-channel differential input devices.

## CS5516, CS5520

### 16 or 20 bit Bridge Transducer ADC

- \* On-chip instrumentation amplifier
- \* On-chip demodulators
- \* On-chip PGA
- \* 4-bit D/A for offset removal

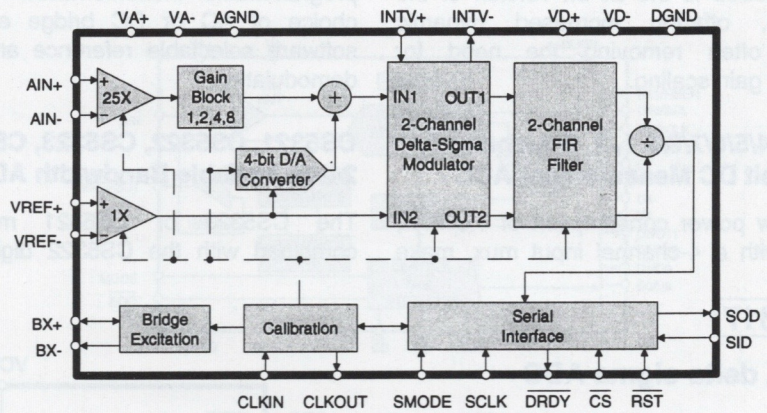

## CS5321, CS5322, CS5323

### 24 bit ADC chip set

- \* 120 dB dynamic range
- \* Delta-sigma modulator
- \* Variable bandwidth digital filter: 26/51/103/206/412/824/1652 Hz
- \* Internal track & hold
- \* Low power consumption

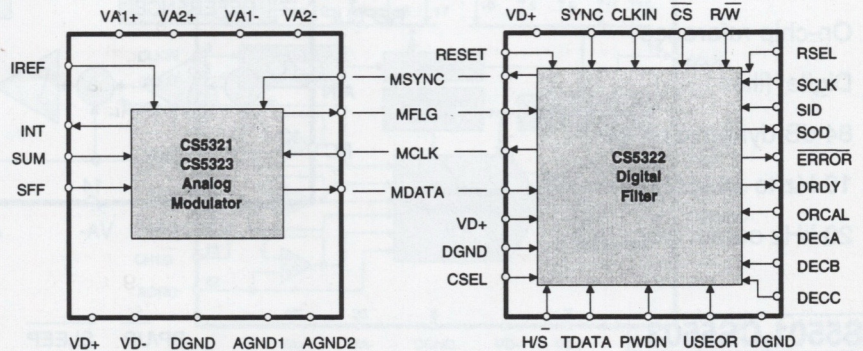

## CS5324

### 120 dB dynamic range ADC

- \* Delta-sigma modulator
- \* 1st stage FIR filter
- \* 32 kHz output word rate
- \* Internal track & hold
- \* Low power consumption

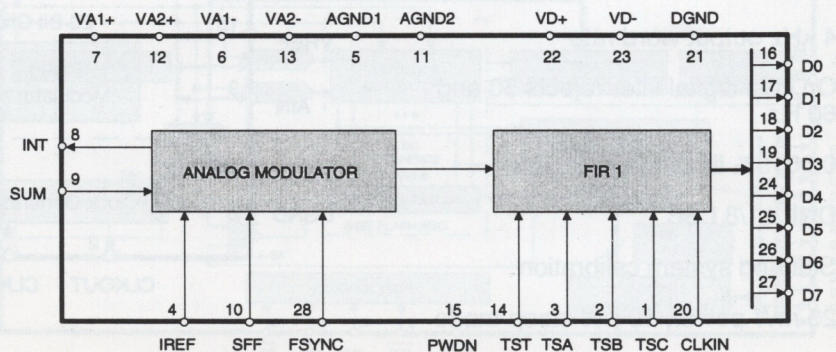

# DIGITAL AUDIO PRODUCTS

## Digitally Controlled Volume Control

The CS3310 is a stereo volume control, allowing analog volume level adjustment from -98 dB to +30 dB in 0.5 dB steps. Low glitch circuit design ensures no "zipper" noise.

## Multimedia Stereo Audio Codecs

The CS4215, CS4216, CS4231, and CS4248 are complete audio coders/decoders. Each device contains 2 16-bit A/D converters, 2 16-bit D/A converters, adjustable input gain and adjustable output level. Both digital and analog filtering is included, so no external analog filters are required. The CS4215 and CS4216 have serial digital ports for easy connection to DSP's and workstations. The CS4131 is a PC-ISA bus to CS4215 interface chip. The CS4231 and CS4248 have parallel digital ports compatible with PC-ISA and EISA bus standards. Using DMA channels, high quality audio can be recorded and played back from a PC hard disk. Windows drivers for the CS4131/CS4215, CS4231, and CS4248 are available.

## CS4225 Two ADC, Four DAC Codec

Intended for automotive and surround sound applications, the CS4225 includes two 16-bit ADCs with input level adjustment and four 16-bit DACs each with volume adjust. A built-in PLL allows operation from word rate clocks.

## CS4303 18-bit D/A Converter

The CS4303 is an all digital I.C. containing an 8X interpolation filter and overall 64X oversampling delta-sigma modulator.

Addition of an external analog reconstruction filter yields 107 dB dynamic range with superb low level linearity.

## CS4328 18-bit D/A Converter

The CS4328 is a complete stereo digital-to-analog output system. Included are an 8X interpolation filter, 64X Delta-Sigma modulator, 1-bit D/A converter and a 124 dB signal-to-noise ratio analog anti-imaging filter, all in one packaged, tested, solution.

## CS4332 Low Cost D/A Converter

Offering 90 dB Dynamic Range and a built-in volume control, the CS4332 offers the best performance / price / power consumption balance available today.

## CS4920 Audio Decoder-DAC

The CS4920 combines a 16.5 mips DSP with a stereo 16-bit DAC. Crystal provides DSP code for MPEG and Dolby decompression algorithms.

## CS5326,7,8,9 and CS5336,8,9 Delta Sigma Audio A/D Converters

The CS5326 family features 64X oversampling, using a Delta-Sigma architecture with resolutions of 16 or 18-bits. Output word rates can be from 1 kHz to 50 kHz. These stereo parts have 2 sample and holds, dual Delta-Sigma modulators, two anti-aliasing and decimation filters, and a voltage reference, all in a 28-pin package.

## CS5345 and CS5349 Single Supply, Stereo A/D Converters.

The CS5345 and CS5349 are complete, 16-bit A/D converters for stereo digital

audio systems that only require a single +5V supply.

## CS5389 and CS5390 18/20-bit Stereo A/D Converters

The CS5389 and CS5390 A/D converters have differential input circuits to the delta-sigma modulator, achieving a dynamic range of 110 dB.

## AES/EBU & S/PDIF Transmitters & Receivers and Audio LAN

The CS8401A/2A digital audio transmitters, along with the CS8411/2 digital audio receivers, allow digital communication between audio equipment. These IC's support both the professional AES/EBU and consumer S/PDIF formats. The CS8411 and CS8412 receivers have low-jitter, on-chip clock recovery.

The CS8425 audio local area network (A-LAN) transceiver allows multiple digital audio devices to be connected together on a single wire (or fiber-optic). The data format is S/PDIF, with the user channel bits utilized as message information. The A-LAN is for use in car sound systems and distributed home entertainment systems. The CS8425 may also be used as a stand-alone S/PDIF transceiver.

## CS8903 and CS9203 Audio Synthesizers

These devices use wave table synthesis for superb sound quality at an affordable price. The CS8903 is a programmable effects DSP, while the CS9203 is a dedicated synthesizer.

## Audio A/D Converter Table

Device	CS5326	CS5327	CS5328	CS5329	CS5336	CS5338	CS5339	CS5345	CS5349	CS5389	CS5390
Number of Bits	16	16	18	18	16	16	16	16	16	18	20
Dynamic Range (dB)	95	95	97/100*	97/100*	95	95	95	91	90	107	110
SOIC Package	-	-	-	-	✓	✓	✓	✓	✓	-	-
Filter Passband (kHz)	0-22	0-20	0-22	0-20	0-20	0-22	0-22	0-18	0-22	0-22	0-22
Filter Transition Band (kHz)	22-26	20-24	22-26	20-24	20-26	22-28	22-28	18-32	22-28	22-28	22-28
Stop Band Attenuation (dB)	-86	-86	-86	-86	-80	-80	-80	-73	-80	-80	-98
Overrange Tag Bits	-	-	-	-	✓	✓	✓	-	✓	-	-
Left/Right Tag Bits	-	-	-	-	✓	✓	✓	-	✓	-	-
Master Clocking Mode	-	-	-	-	✓	✓	✓	-	✓	✓	✓
SCLK active edge	↑	↑	↑	↑	↑	↑	↓	↓	↓	↓	↓
Master Clock Frequency (XFs)	128	128	128	128	256/384	256/384	256/384	256/384	256/384	256/384	256/384
Power Supply Voltages (V)	±5	±5	±5	±5	±5	±5	±5	+5	+5	±5	±5
Operation < 30 kHz without TEST Mode	-	-	-	-	✓	✓	✓	✓	✓	✓	✓
Power Consumption mW	450	450	450	450	400	400	400	100	325	550	550

\* In Mono Mode

All frequencies are with an output word rate of 48 kHz



# DIGITAL AUDIO PRODUCTS

## CS4225

### 4 DAC, 2 ADC Automotive Codec

- \* Stereo 16-bit ADC
- \* Quad 16-bit DAC
- \* Fs from 4 to 50 kHz
- \* On-chip PLL

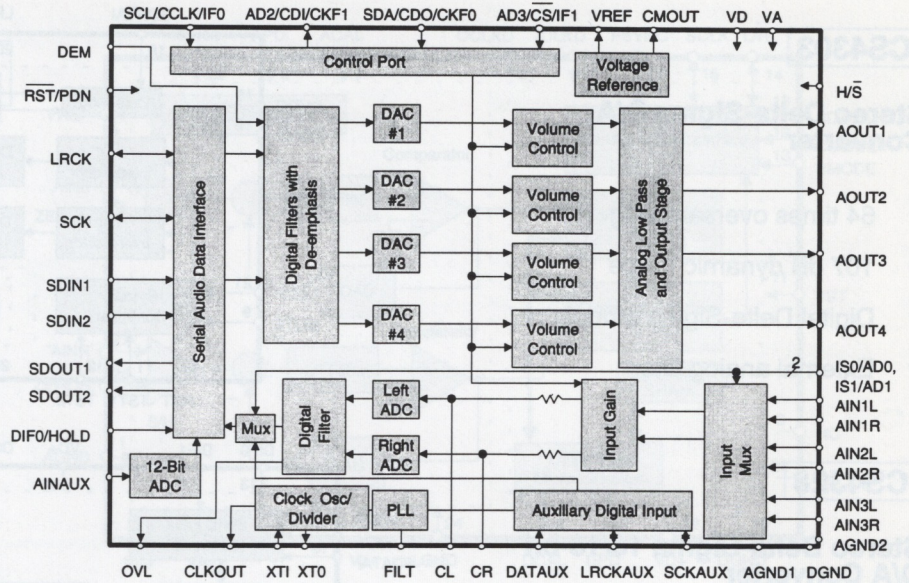

## CS4231

### Parallel Interface, Multimedia Audio Codec

- \* Pin Compatible with CS4248/AD1848 with extra features
- \* ADPCM Compression/Decompression
- \* MPC Compatible Mixer
- \* Dual DMA Count Registers for Full Duplex Operation
- \* 8-bit DMA Audio Transfers to and from Host PC with On-chip FIFO's
- \* Timer Register for Audio/Video Synchronization
- \* 16 mA Bus Drive Capability
- \* Digital 3.3/5V Operation

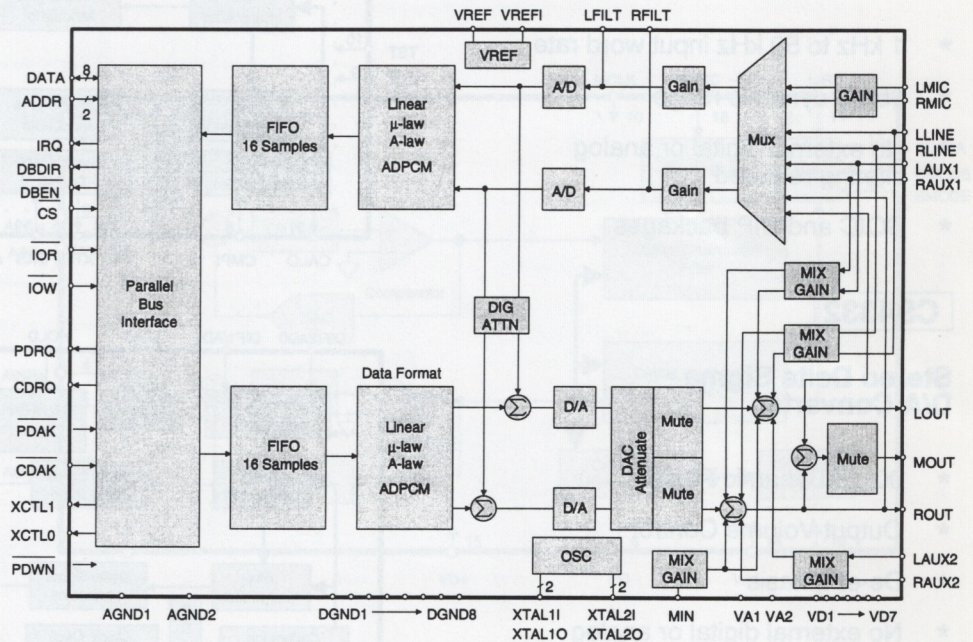

## CS4248

### Parallel Interface, Multimedia Audio Codec

- \* Integrated Parallel Interface to ISA and EISA Buses
- \* Support for Stereo Digital Audio at Sample Rates from 4kHz to 50kHz with 16 bit Resolution
- \* 8 bit DMA Transfers of Audio Data to and from Host PC
- \* Support for one or two DMA Channels
- \* Analog and Digital Signal Mixing
- \* Optional μ-law and A-law Coding
- \* Pin Compatible with AD1848

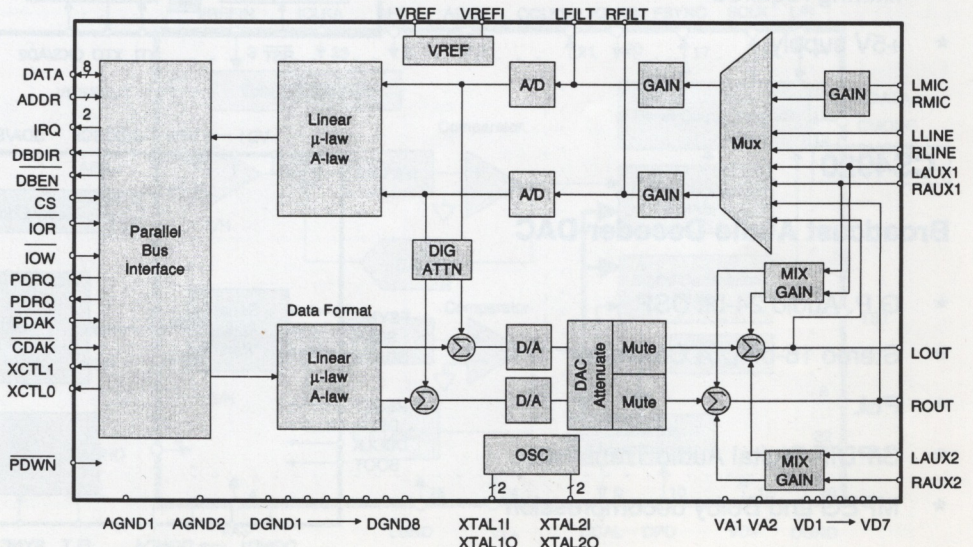

# DIGITAL AUDIO PRODUCTS

## CS4303

### Stereo Delta-Sigma D/A Converter

- \* 64 times oversampling
- \* 107 dB dynamic range
- \* Digital Delta-Sigma modulator
- \* External analog filter

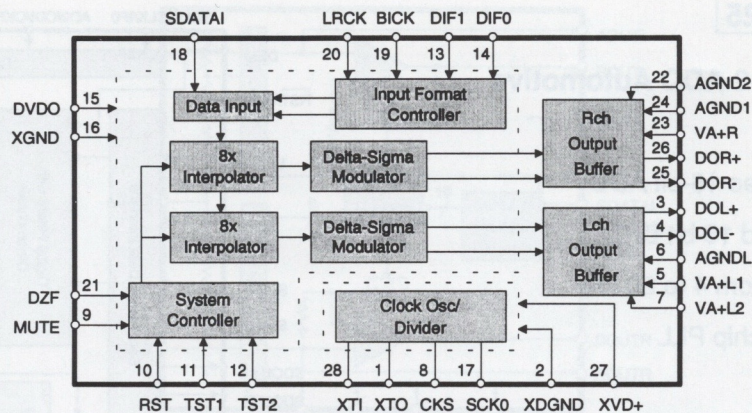

## CS4328

### Stereo Delta-Sigma 18/16-bit D/A Converter

- \* 1 kHz to 50 kHz input word rate
- \* 95 dB dynamic range
- \* No external digital or analog filtering required
- \* SOIC and DIP packages

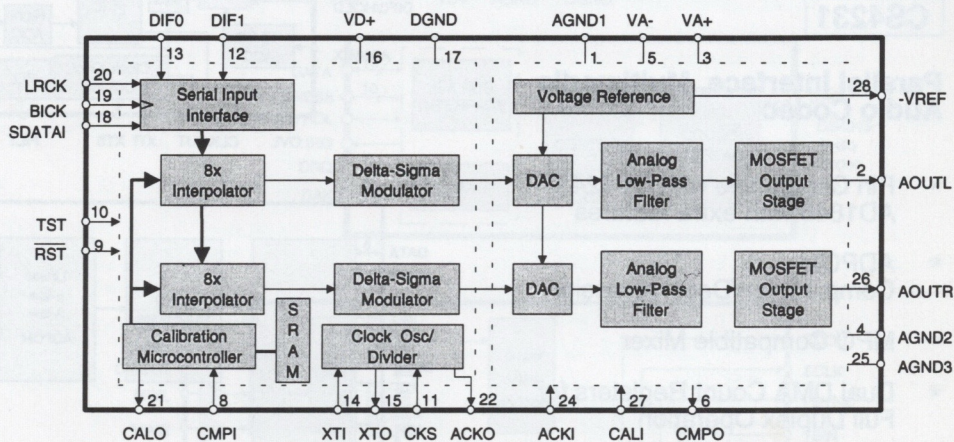

## CS4332

### Stereo Delta Sigma D/A Converter

- \* 90 dB Dynamic Range
- \* Output Volume Control
- \* De-emphasis
- \* No external digital or analog filtering required
- \* +5V supply

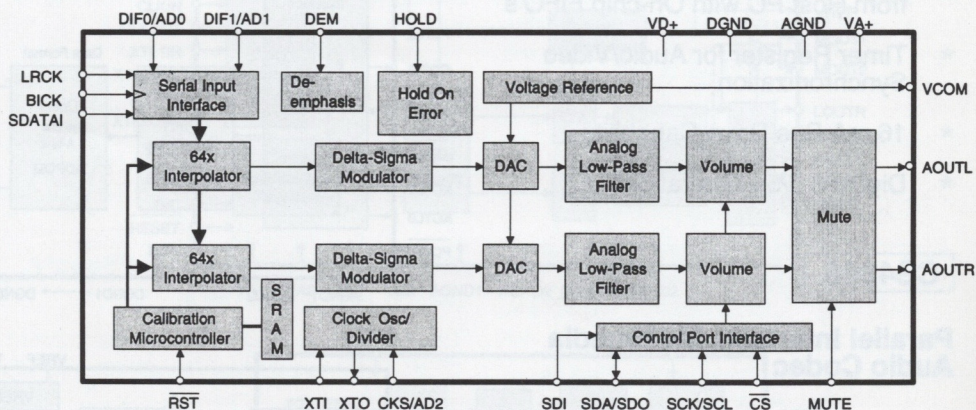

## CS4920

### Broadcast Audio Decoder-DAC

- \* G.P. Audio 24-bit DSP
- \* Stereo 16-bit D/A Converter
- \* PLL
- \* S/PDIF Digital Audio Transmitter
- \* MPEG and Dolby decompression

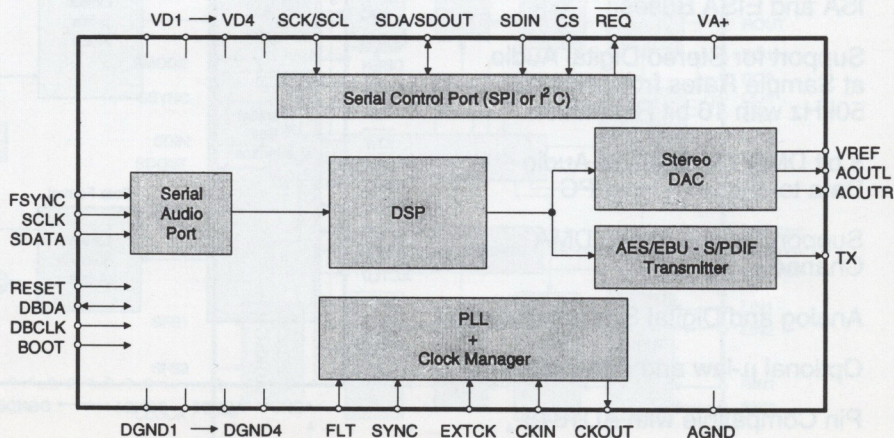

# DIGITAL AUDIO PRODUCTS

## CS5326, CS5327, CS5328, CS5329, CS5336, CS5338, CS5339

### Low Cost Stereo Delta-Sigma A/D Converter 16/18-bit

- \* 1 kHz to 50 kHz output word rate
- \* 95 dB dynamic range
- \* Internal 64X oversampling
- \* SOIC and DIP packages
- \* Master mode clocking
- \* 256 Fs or 384 Fs clock

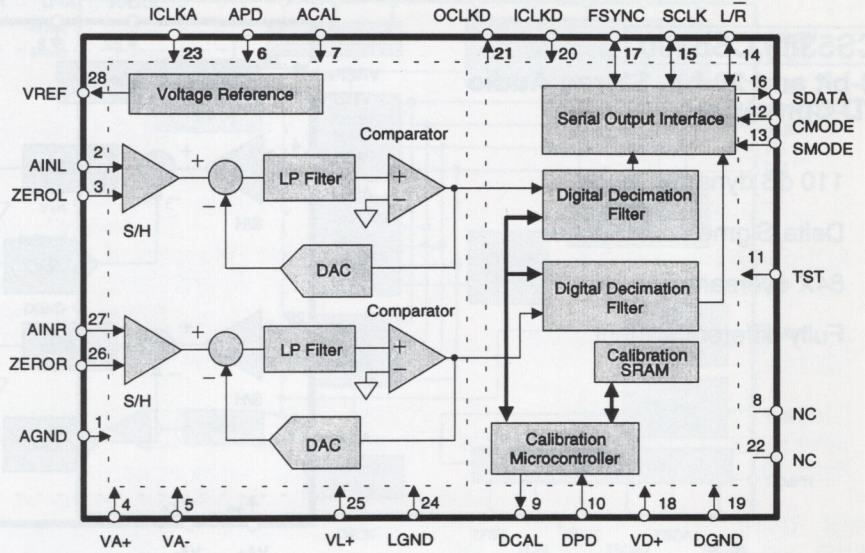

## CS5345

### Single Supply, Stereo A/D Converter

- \* +5V Only Power Supply
- \* 91 dB Dynamic Range (A-weighted)
- \* Linear Phase Digital Anti-Alias Filtering
- \* Low Power Dissipation: 100 mW
- \* 1 kHz to 50 kHz Word Rate
- \* Internal 64X Oversampling

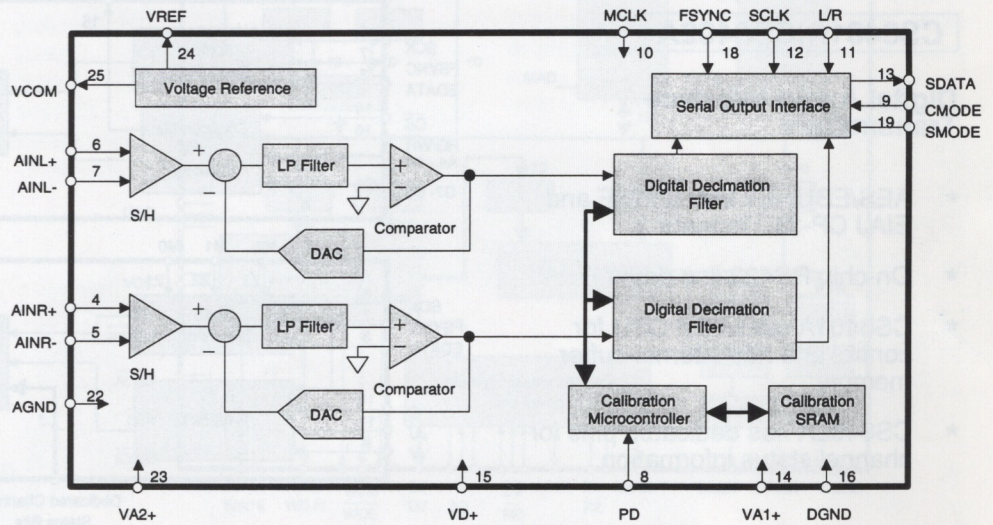

## CS5349

### Stereo +5V Supply Delta-Sigma Converter

- \* +5V only supply
- \* 1 kHz to 50 kHz word rate
- \* 90 dB dynamic range
- \* Internal 64X oversampling
- \* SOIC & DIP packages
- \* 256 Fs or 384 Fs clock

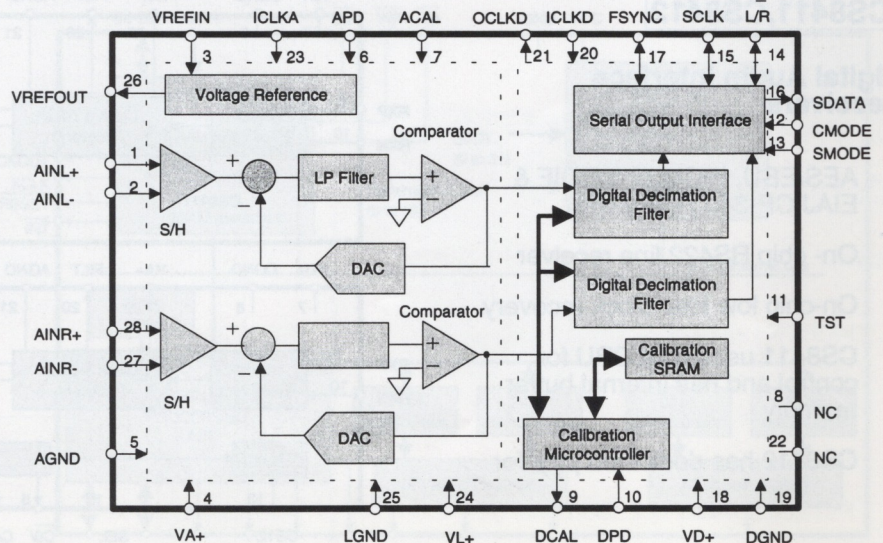

# DIGITAL AUDIO PRODUCTS

## CS5389, CS5390

### 18-bit and 20-bit, Stereo Audio A/D Converters

- \* 110 dB dynamic range
- \* Delta-Sigma architecture
- \* 64X oversampling
- \* Fully differential input

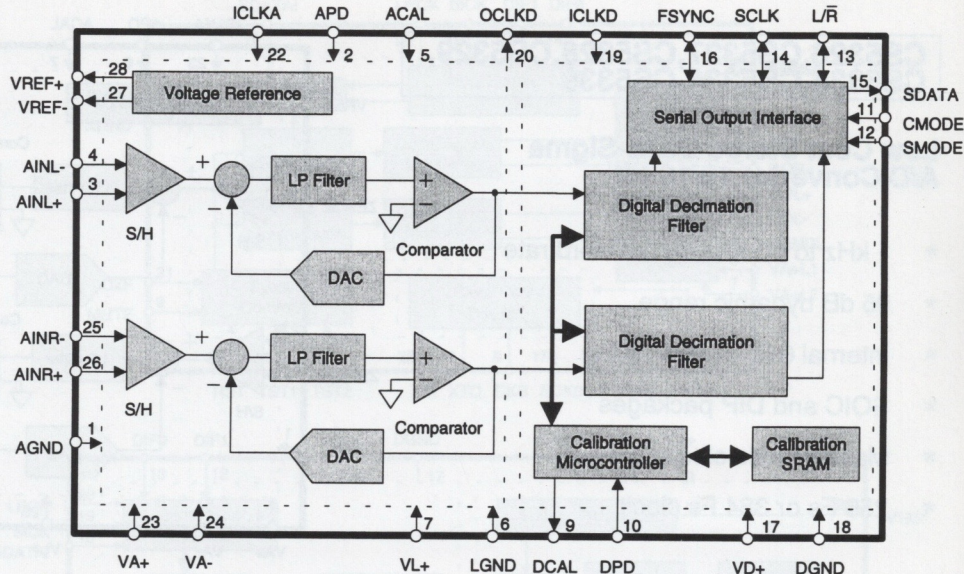

## CS8401A, CS8402A

### Digital Audio Interface Transmitters

- \* AES/EBU, IEC958 S/PDIF and EIAJ CP-340 formats
- \* On-chip RS422 line driver
- \* CS8401A uses host CPU for control and has internal buffer memory
- \* CS8402A has dedicated pins for channel status information

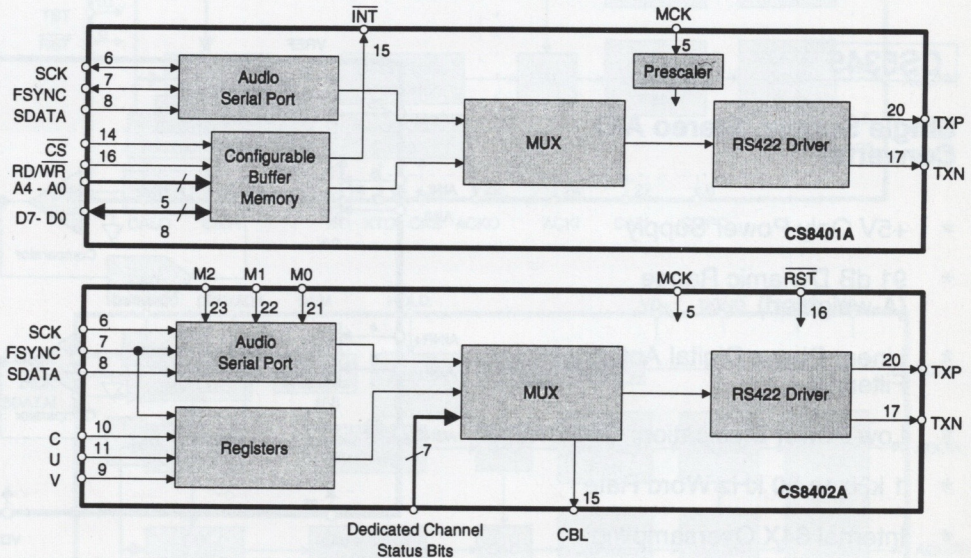

## CS8411, CS8412

### Digital Audio Interface Receivers

- \* AES/EBU, IEC958, S/PDIF & EIAJ CP-340 Formats
- \* On-chip RS422 line receiver
- \* On-chip low jitter clock recovery
- \* CS8411 uses host CPU for control and has internal buffer memory
- \* CS8412 has dedicated pins for

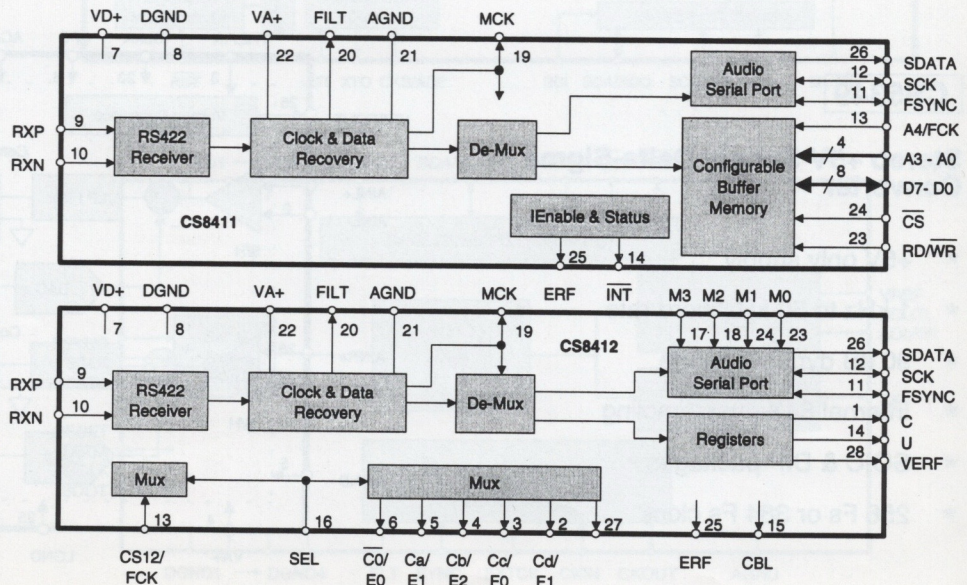

# DIGITAL AUDIO PRODUCTS

## CS8425

### Audio Local Area Network Transceiver (A-Lan)

- \* EIAJ-CP340 and SPDIF Formats
- \* Message passing via user bits
- \* Multiple nodes per LAN
- \* Also a general purpose SPDIF transceiver

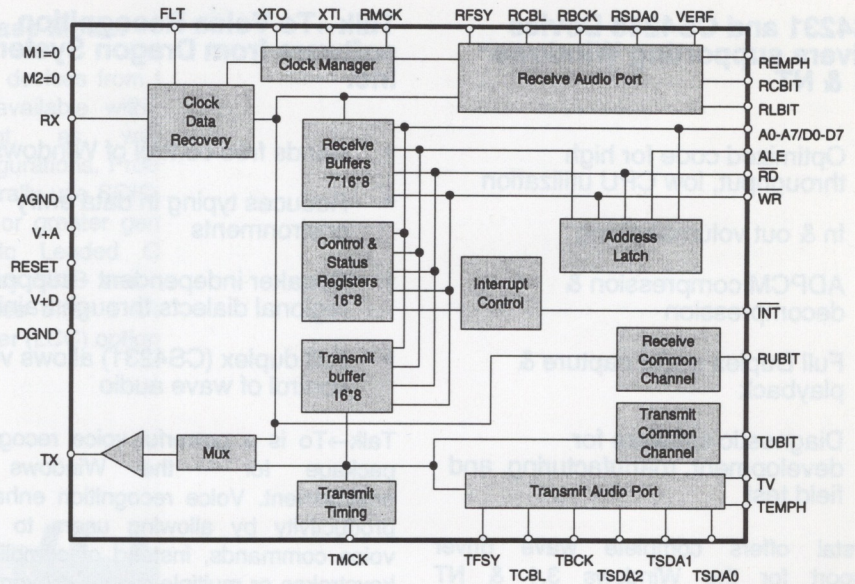

## CS8905

### Programmable Music Processor

- \* Programmable as WaveTable synthesizer or effects processor
- \* Polyphonic up to 16 notes
- \* Multi-timbral up to 16 simultaneous timbres
- \* Stereo 16-bit digital audio output
- \* Directly addresses up to 1M x 12 of WaveTable Sample ROM

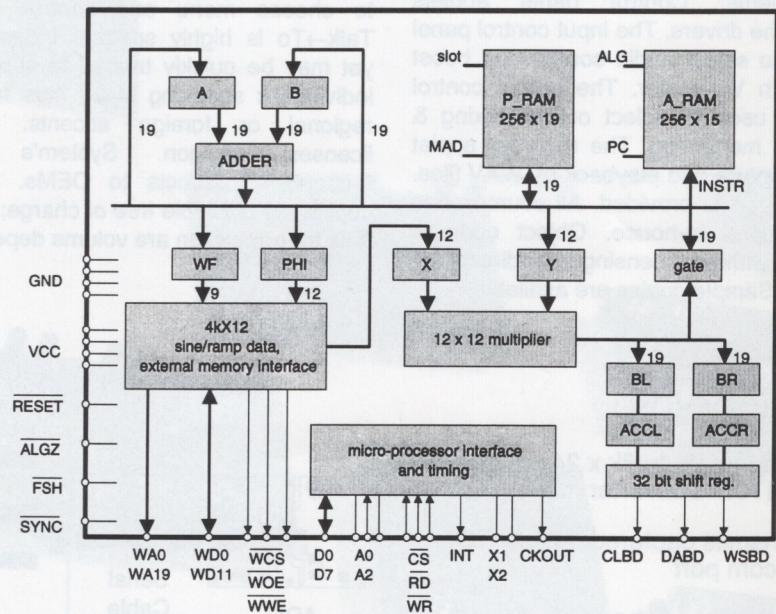

## CS9203

### Advanced WaveTable Synthesizer

- \* General MIDI compliant, compatible to GS
- \* Polyphonic up to 32 notes
- \* Multi-timbral up to 32 simultaneous timbres
- \* 15 built-in synthesis algorithms
- \* 2 stereo 16-bit digital audio outputs
- \* Addresses up to 8M x 12 of WaveTable Sample ROM

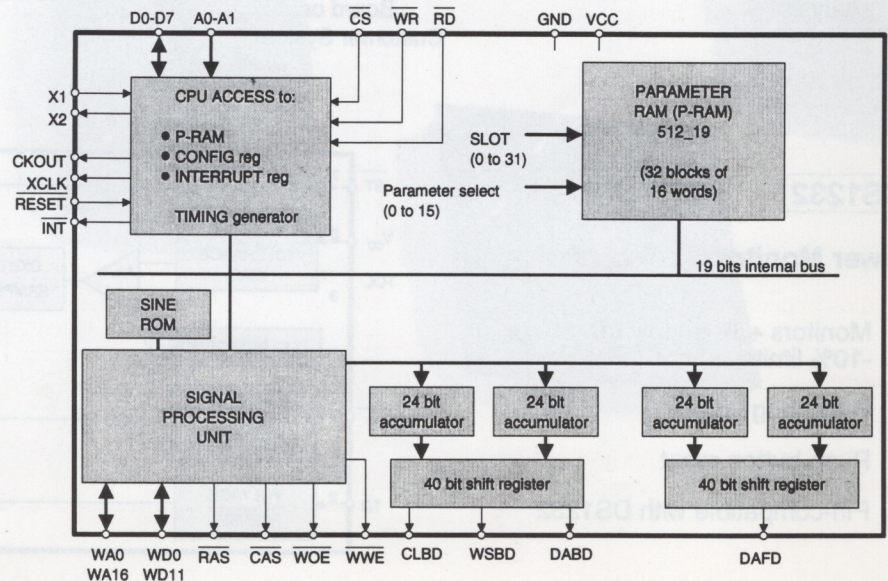

# SUPPORT PRODUCTS

## CS4231 and CS4248 Device Drivers supporting Windows™ 3.1 & NT

- \* Optimized code for high throughput, low CPU utilization
- \* In & out volume/mixing
- \* ADPCM compression & decompression
- \* Full Duplex audio capture & playback
- \* Diagnostic software for development, manufacturing, and field test

Crystal offers complete wave driver support for the Windows 3.1 & NT environments. Control panel applets support the drivers. The input control panel is used to select audio source and boost level, with VU meter. The output control panel is used to select output mixing & loopback monitoring. The recorder applet allows capture and playback of .WAV files. OLE support is provided. All source code is developed in-house. Object code is provided without licensing fees directly by Crystal. Sample copies are available.

## Talk→To Voice Recognition software from Dragon Systems, Inc.

- \* Hands free control of Windows 3.1
- \* Reduces typing in data entry environments
- \* Speaker independent - supports regional dialects through training
- \* Full duplex (CS4231) allows voice control of wave audio

Talk→To is a powerful voice recognition package for the Windows 3.1 environment. Voice recognition enhances productivity by allowing users to enter voice commands, instead of complicated keystrokes or multiple mouse movements, to choose menu and control options. Talk→To is highly speaker independent, yet may be quickly trained to support an individual's speaking style, thus handling regional or foreign accents. Crystal licenses Dragon System's voice recognition products to OEMs. Sample copies are available free of charge; license fees for production are volume dependent.

## Monologue Text-To-Speech synthesis software from First Byte.

- \* Allows Windows applications to speak
- \* Permits efficient proof-reading of text and numerical data
- \* Multilingual: French, German, Spanish and American available now; Italian, British and Japanese in development
- \* Transfer data through clipboard or direct DLL/DDE link

Monologue increases productivity by allowing users to add speech capabilities to any Windows (or DOS) application. Any pronounceable combination of letters and numbers will be spoken clearly. Volume, pitch and speed are user adjustable. An exception dictionary allows preferred pronunciations. Crystal licenses First Byte's Monologue family of products to OEMs. Sample copies are available free of charge; license fees for production are volume dependent.

## CDBCAPTURE

- \* Captures up to 8k x 24 words from A/D Converter
- \* Transmits captured data to PC via com port
- \* LabWindows® based software allows FFT & Time domain analysis

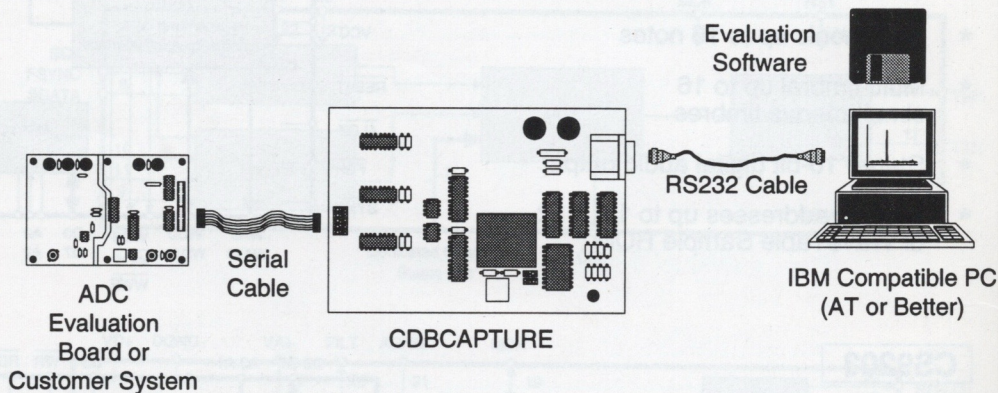

## CS1232

### Power Monitor

- \* Monitors +5V supply for -5% or -10% limits
- \* Watchdog timer
- \* Push-button reset
- \* Pin-compatible with DS1232

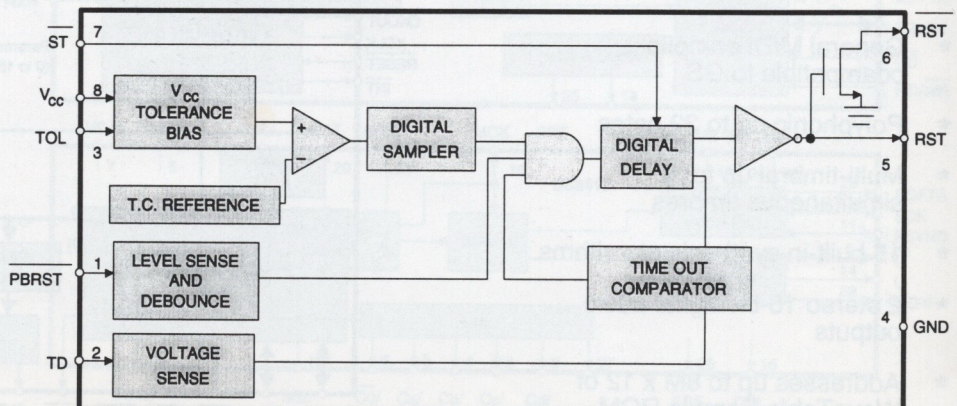

# CUSTOMER SUPPORT

## Evaluation Boards and Design Tools

When it comes to support tools for analog circuits, there is none better than Crystal Semiconductor. It starts with our world-class documentation. Our data sheets go far beyond listing device specification and pin assignments. They have all the information needed for a quick design cycle. Most include applications and design hints. All are clearly written and precise. Use the response card to request copies of our latest data books.

Each of our major products is supported with an evaluation board. These high quality boards allow fast device evaluation and often eliminate initial breadboarding. Many users find the layout and ground schemes useful as guidelines in system board design. Finally, our boards can be helpful in the isolation of system problems by comparing in-system performance to the evaluation board performance.

## Applications Support

Crystal Semiconductor has one of the best applications engineering groups in the industry. Our specialists are well-versed in our products and their applications. Most have had extensive systems experience, and all are experts on our family of devices. If you have technical or design questions, these professionals will have the answers.

## Military 883

Most Crystal Semiconductor devices are designed to operate over military temperature ranges. We can now offer MIL STD 883C Class B compliant production on many of our data acquisition circuits. The CS5012, CS5014, CS5016, CS5101A, CS5102A and CS5412 ADC's have been assigned Standard Military Drawing Numbers by DESC.

## Die Availability

Many Crystal Semiconductor products are supplied in die form to the hybrid IC manufacturing industry. Die data sheets are available on most data acquisition products. Please contact the factory for further information.

## Surface Mount

Most devices from Crystal Semiconductor are available with packaging in surface mount, as well as through-hole configurations. Products of 24 pins or less generally use SOIC packages. Parts of 28 pins or greater generally are available in Plastic Leaded Chip Carrier (PLCC). Military 883B and other high temperature devices offer a Ceramic Leadless Chip Carrier (LCC) option.

## Sales and Customer Support

Crystal Semiconductor has a sales and support organization which spans the globe. Our sales offices are located in over 20 countries and over 40 cities in the United States and Canada. They are backed by a factory support team that is first rate. Answers to your questions are as close as your local sales representative or area sales office shown overleaf.

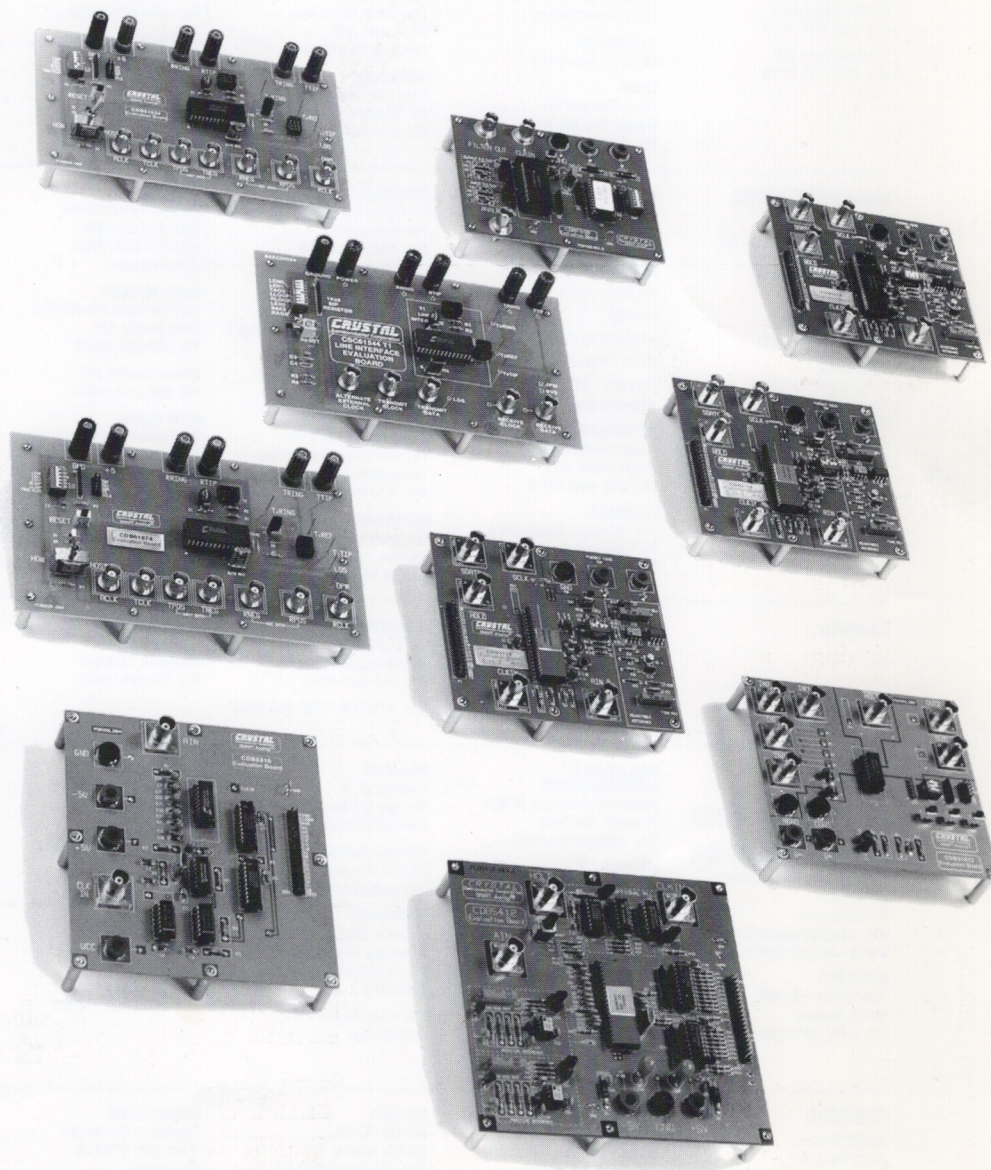



**CRYSTAL SEMICONDUCTOR CORPORATION**  
 P.O. Box 17847, 4210 S. Industrial Dr., Austin, Tx. 78744  
 Tel: (512)445-7222, (800) 888-5016 Fax: (512)445-7581

**U.S. AREA SALES OFFICES  
 and  
 APPLICATIONS SUPPORT**

**WESTERN AREA**

Crystal Semiconductor Corp.  
 San Jose, CA  
 Ph: 408-437-7743  
 FAX: 408-437-4943

Crystal Semiconductor Corp.  
 Mission Viejo, CA  
 Ph: 714-348-8770  
 FAX: 714-348-9556

**CENTRAL AREA**

Crystal Semiconductor Corp.  
 Austin, TX  
 Ph: 512-445-7222  
 FAX: 512-445-7581

**EASTERN AREA**

Crystal Semiconductor Corp.  
 Raleigh, NC  
 Ph: 919-846-4832  
 FAX: 919-846-4839

Crystal Semiconductor Corp.  
 Salem, NH  
 Ph: 603-894-5544  
 FAX: 603-894-5533

**UNITED STATES**

**ALABAMA**  
 CP&F, Inc.  
 Huntsville, AL  
 Ph: 205-536-1506

**ARIZONA**  
 Western High Tech Marketing, Inc.  
 Scottsdale, AZ  
 Ph: 602-860-2702

**CALIFORNIA**  
 Earle Associates, Inc.  
 San Diego, CA  
 Ph: 619-278-5441

Bager Electronics  
 Fountain Valley, CA  
 Ph: 714-957-3367

Woodland Hills, CA  
 Ph: 818-712-0011

**NORCOMP, Inc.**  
 Santa Clara, CA  
 Ph: 408-727-7707

Granite Bay, CA  
 Ph: 916-791-7776

**COLORADO**

PromoTech  
 Denver, CO  
 Ph: 303-692-8484

**FLORIDA**  
 CP&F Florida, Inc.  
 Orlando, FL  
 Ph: 407-855-0843

**GEORGIA**  
 CP&F Florida, Inc.  
 Duluth, GA  
 Ph: 404-497-9404

**ILLINOIS (NORTH)**  
 Micro Sales Inc.  
 Itasca, IL  
 Ph: 708-285-1000

**INDIANA**  
 TMC Electronics  
 Carmel, IN  
 Ph: 317-844-8462

Ft. Wayne, IN  
 Ph: 219-432-5553

Kokomo, IN  
 Ph: 317-459-5152

**IOWA**

Stan Clothier Co.  
 Cedar Rapids, IA  
 Ph: 319-393-1576

**KANSAS**

Stan Clothier Co.  
 Lenexa, KS  
 Ph: 913-492-2124

**KENTUCKY**  
 TMC Electronics  
 Louisville, KY  
 Ph: 502-245-7411

**MARYLAND**  
 New Era Sales, Inc.  
 Glen Burnie, MD  
 Ph: 410-761-4100

**MASSACHUSETTS**  
 Alpha-Omega Sales Corp.  
 North Reading, MA  
 Ph: 508-664-1118

**MICHIGAN**  
 J.M.J. & Associates, Inc.  
 Grand Rapids, MI  
 Ph: 616-285-8887

**MINNESOTA**  
 The Twist Company  
 Plymouth, MN  
 Ph: 612-550-0922

**MISSOURI**  
 Stan Clothier Co.  
 St. Charles, MO  
 Ph: 314-928-8078

**NEW JERSEY (NORTH)**

Nexus Technology Sales  
 Fort Lee, NJ  
 Ph: 201-947-0151

**NEW JERSEY (SOUTH)**  
 Vantage Sales Company  
 Cherry Hill, NJ  
 Ph: 609-424-6777

**NEW YORK**  
 Bob Dean, Inc.  
 Ithaca, NY  
 Ph: 607-257-1111

Wappingers Falls, NY  
 Ph: 914-297-6406

**NORTH CAROLINA**  
 CP&F Atlantic, Inc.  
 Greensboro, NC  
 Ph: 919-852-4498

**OHIO**  
 TMC Electronics  
 Cincinnati, OH  
 Ph: 513-271-3860

Middleburg Heights, OH  
 Ph: 216-885-5544

**OREGON**

Electronic Engineering Sales  
 Portland, OR  
 Ph: 503-639-3978

**TEXAS**  
 TL Marketing, Inc.  
 Austin, Texas  
 Ph: 512-371-7272

Houston, Texas  
 Ph: 713-587-8100

Dallas, Texas  
 Ph: 214-490-9300

**UTAH**  
 Anderson Associates  
 Bountiful, UT  
 Ph: 801-292-8991

**VIRGINIA**  
 New Era Sales, Inc.  
 Charlottesville, VA  
 Ph: 804-979-2470

**WASHINGTON**  
 Electronic Engineering Sales  
 Kirkland, WA  
 Ph: 206-889-2988

**U. S. DISTRIBUTORS**

**ALABAMA**  
 Repron Electronics, Inc.  
 Huntsville, AL  
 Ph: 205-722-9500

Nu Horizons  
 Huntsville, AL  
 Ph: 205-722-9330

**ARIZONA**  
 Insight Electronics  
 Tempe, AZ  
 Ph: 602-829-1800 (Tempe)  
 Ph: 602-792-1800 (Tucson)  
 Ph: 505-823-1800 (New Mexico)

**CALIFORNIA**

Insight Electronics  
 West Lake Village, CA  
 Ph: 818-707-2101  
 (San Fernando Valley)

Ph: 714-727-3291  
 (Irvine)

Ph: 619-587-1100  
 (San Diego)

Ph: 408-720-9222  
 (Sunnyvale)

**COLORADO**  
 Insight Electronics  
 Englewood, CO  
 Ph: 303-649-1800

**FLORIDA**  
 Nu Horizons Electronics  
 Ft. Lauderdale, FL  
 Ph: 305-735-2555

**GEORGIA**

Nu Horizons Electronics  
 Norcross, GA  
 Ph: 404-416-8666

**ILLINOIS**  
 Repron Electronics  
 Schamburg, IL  
 Ph: 708-882-1700 (Chicago)

**MARYLAND**  
 Nu-Horizons Electronics  
 Columbia, MD  
 Ph: 410-995-6330

**MASSACHUSETTS**  
 Nu-Horizons Electronics  
 Wakefield, MA  
 Ph: 617-246-4442

**MICHIGAN**  
 Repron Electronics  
 Livonia, MI  
 Ph: 313-525-2700 (Detroit)

**MINNESOTA**

Repron Electronics  
 Minnetonka, MN  
 Ph: 612-938-0000  
 (Minneapolis)

**NEW JERSEY**  
 Nu-Horizons Electronics  
 Pine Brook, NJ  
 Ph: 201-882-8300

Mount Laurel, NJ  
 Ph: 609-231-0900

**NEW YORK**  
 Nu-Horizons Electronics  
 Rochester, NY  
 Ph: 716-292-0777

North Amityville, NY  
 Ph: 516-226-6000

**NORTH CAROLINA**

Repron Electronics  
 Raleigh, NC  
 Ph: 919-870-5189

**OHIO**  
 Repron Electronics  
 Solon, OH  
 Ph: 216-349-1415  
 (Cleveland)

**OREGON**  
 Insight Electronics  
 Beaverton, OR  
 Ph: 503-644-3300

**TEXAS**  
 Insight Electronics  
 Richardson, TX  
 Ph: 214-783-0800 (Dallas)  
 Ph: 817-338-0800 (Ft. Worth)

Ph: 713-448-0800  
 (Sugarland)

Ph: 512-331-5887  
 (Austin)

**WASHINGTON**  
 Insight Electronics  
 Kirkland, WA  
 Ph: 206-820-8100

**CANADA**

**BRITISH COLUMBIA**

MICROWE Electronics Corp.  
 Delta, BC  
 Ph: 604-943-5020

**ONTARIO**

InTELaTECH  
 Mississauga, Ontario  
 Ph: 416-629-0082  
 Ph: 613-253-1369 (Kanata)

**QUEBEC**

InTELaTECH  
 Kirkland, Quebec  
 Ph: 514-630-6041

**EUROPE**

**EUROPE SALES OFFICE  
 and  
 APPLICATIONS SUPPORT**

Crystal Semiconductor (UK) Ltd.  
 Frimley, U.K.  
 Ph: +44(0276)685761  
 FAX: +44(0276)691090

**AUSTRIA**  
 Transistor-Hitronik  
 Wien, Austria  
 Ph: +43(1)601290

**BELGIUM &  
 LUXEMBOURG**

Alcom Electronics BVBA  
 Kontich, Belgium  
 Ph: +32(0345)83033

**DENMARK**  
 Scansupply A/S  
 Soebord, Denmark  
 Ph: +45(039)665090

Ph: +45(086)127788  
 (Aarhus C.)

**FINLAND**  
 Integrated Electronics OyAB  
 Helsinki, Finland  
 Ph: +358(0)3513133

**FRANCE**

Newtek S. A.  
 Rungis Cedex, France  
 Ph: +33(01468)72200

Newtek Sud-Est  
 CLAIX, France  
 Ph: +33(076)985601

**GERMANY**  
 Atlantik Elektronik GmbH  
 Planegg, Germany  
 Ph: +49(089)8570000  
 (Munich)

Ph: +49(040)241072  
 (Hamburg)

**HOLLAND**

Alcom Electronics BV  
 Capelle A/D IJSSEL,  
 Holland  
 Ph: +31(010)4519533

**ITALY**  
 Newtek Italia S.p.A.  
 Milano, Italy  
 Ph: +39(233)105308

**ISRAEL**  
 Telsys  
 Tel-Aviv, Israel  
 Ph: +972(03)492001

**NORWAY**

NC ScandComp Norway AS  
 Oslo, Norway  
 Ph: +47(22)500650

**SPAIN & PORTUGAL**  
 Amitron SA  
 Madrid, Spain  
 Ph: +34(91)5420906

**SWEDEN**  
 Ab Gosta Backstrom  
 Stockholm, Sweden  
 Ph: +46(086541)080

**SWITZERLAND**

Memotec AG  
 Langenthal, Switzerland  
 Ph: +41(063)281-122

**UNITED KINGDOM**  
 Sequoia Technology Ltd.  
 Reading, United Kingdom  
 Ph: +44(0734)311822

**FAR EAST**

**AUSTRALIA**  
 ACD (N.S.W.)  
 Riverwood, Australia  
 Ph: +61(02)534-6200

ACD (Pegasus)  
 Bayswater, Australia  
 Ph: +61(03)762-7644

**HONG KONG**

CET Ltd.  
 Hong Kong  
 Ph: (852)520-0922

**JAPAN**  
 Asahi Kasei Microsystems Co., Ltd  
 Shibuya-ku, Tokyo, Japan  
 Ph: +81(03)320-2070

**KOREA**

Hanaro Corp.  
 Seoul, Korea  
 Ph: +82(02)516-1144

**MALAYSIA**  
 DCP (M) SDN BHD  
 Penang, Malaysia  
 Ph: +604-281860

**SINGAPORE**

Dynamar Computer Products, Pte Ltd.  
 Singapore  
 Ph: +65-281-3388

**TAIWAN**

Morrihan International Corp.  
 Taipei, Taiwan, R.O.C.  
 Ph: +886(02)752-2200

**THAILAND**

Dynamar Computer Systems  
 Bangkok, Thailand  
 Ph: +662-376-0132